

Foot Mounted Electric Wire Rope Hoist

Hoist model VAT6434TpE3N

Capacity - 20 tonne in FEM9.511 - 2m

Lifting Height - 11.5m

Lifting Speed - 3.0/0.72 m/min

Voltage Supplies - 460, 575V-3ph-60Hz

Rope Reeving - 4/1

Mechanical overload protection (OL)

Optional thermal overload protection (Tp)

Electric panel not shown

Net Weight - 1,310kg

Lifting Motor model KV6001-24/6Tp

Rated power - 3.6/15.6 kW

Switches per hour - 240/120h-1

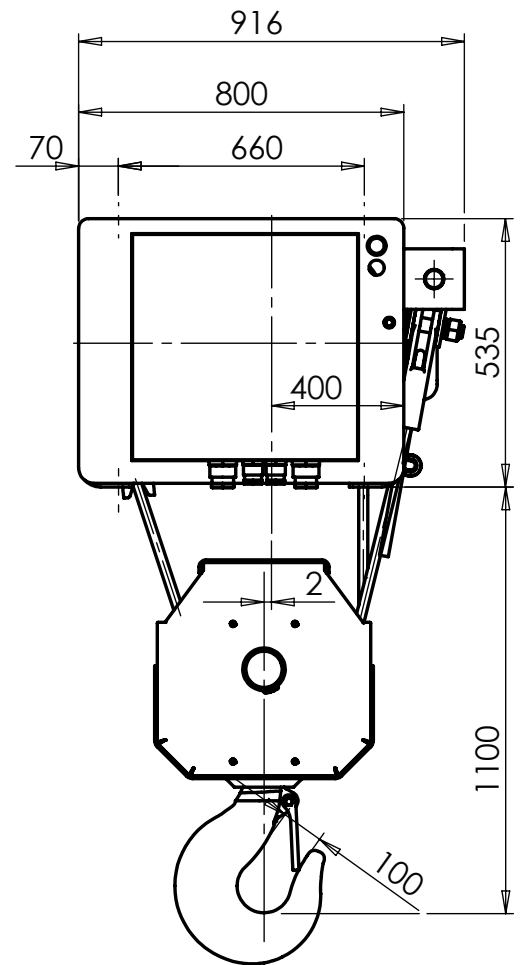
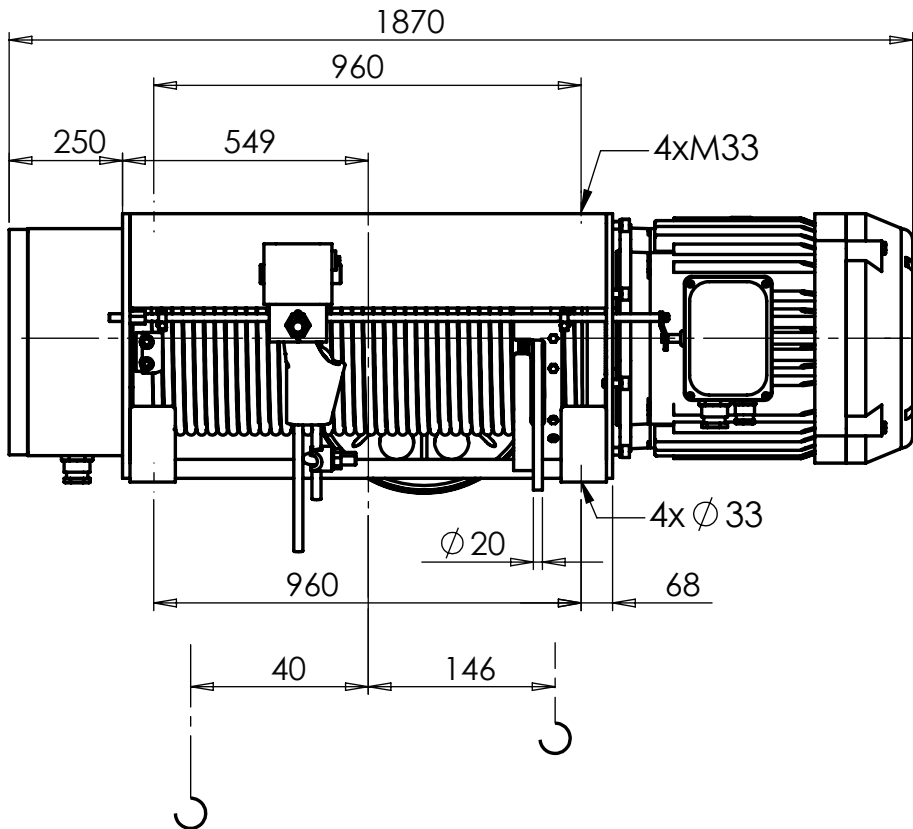

t 604 796 9221 e integrity@hydramachcrane.com
f 604 796 9227 www.hydramachcrane.com

*Dimensions and specifications subject to change without notice.